



**PCOM-SDI**  
RS232 TO SDI-12 COMMUNICATIONS INTERFACE

User Reference Manual

Firmware Revision # 157



Updated: November 8, 2007

<http://www.amassdata.com>

## TABLE OF CONTENTS

<b>1. PCOM-SDI: RS232 TO SDI-12 MASTER INTERFACE .....</b>	<b>3</b>
<b>2. HOST PROTOCOL .....</b>	<b>4</b>
<b>3. SDI-12 PROTOCOL .....</b>	<b>5</b>
<b>4. COMMANDS.....</b>	<b>6</b>
4.1. STANDARD SET .....	6
4.2. FOR SDI-12 SENSORS .....	7
4.2.1. Error Messages .....	7
<b>5. “SPY” MODE.....</b>	<b>8</b>
<b>6. INSTALLATION .....</b>	<b>9</b>
6.1. ELECTRICAL .....	9
6.2. CONNECTORS .....	9
<b>7. SPECIFICATIONS.....</b>	<b>10</b>

# PCOM-SDI

## **RS232 to SDI-12 Communications Interface**

*Pliant Technology Specialists*

---

Pliant: readily yielding to influence

### **1. PCOM-SDI: RS232 to SDI-12 Master Interface**

The AMASSER **PCOM-SDI** provides an interface between RS232 and SDI-12 devices. In its standard configuration it serves as an interface between a RS232 host such as a computer or programmable controller, and a SDI-12 slave such as a sensor. Alternatively, it can also be configured so that the SDI-12 device is the master.

The host PC or PLC requires a protocol-driver that sends and receives ASCII messages that are transferred in the RS232 data stream and uses relaxed timing and no break handling. The "!" character that terminates all SDI-12 commands serves as the delimiter and triggers the PCOM-SDI into action. The host must wait for a response prior to issuing a new command to the PCOM-SDI.

Firmware Support Providing:

- SDI-12 Transparent Mode ( Manual SDI-12 Communications)
- Master SDI-12 task engine, auto retries, auto data buffer retrieval & auto command time-outs
- Simple Host Protocol
- up to 72-byte messages
- Configurable from Auto-retrieve mode to Manual-Retrieve mode (see below)

Hardware Features:

- 1 SDI-12 Serial Digital Interface (10 sensor support) port
- RS-232 Communications Port at **9600 baud: 8 data bits, 2 stop bits, no parity and no flow control**

## 2. HOST PROTOCOL

All messages that are sent and received from the host are ASCII strings transferred in the RS232 data stream with relaxed timing and no break handling. Your RS232 serial port must have the following settings:

- 9600 baud
- 8 data bits
- no parity
- 1 stop bit

For example, if the AMASS Data [PSE-SDI](#) shaft encoder is connected to the SDI-12 bus at address '0', the proper command to obtain a water level reading is "0M0!". To get the reading, therefore, the RS232 host need only send the ASCII string "0M0!" without any timing constraints. Upon receiving the "!" character the AMASSER PCOM-SDI would process the request by issuing the command to the sensor in the manner prescribed by the SDI-12 protocol. The response from the sensor would then be relayed to the host on the RS232 line as an ASCII string in the form: "a+<Response String><CR><LF>". Therefore, the host RS232 device is relieved of all SDI-12 intricacies.

Generally, the command/responses take the following form:

**Host command:** aM0! or aM1! or aM2!, etc..

**PCOM-SDI response to host:** attn<CR><LF>

And 'ttt' seconds later...

**PCOM-SDI response to host:** a+<value #1>+<value #2>+...<CR><LF>

where **a**: Address of the sensor on the SDI-12 bus

**<CR>**: Carriage Return character

**<LF>**: Line Feed character

Alternatively, the PCOM-SDI can be configured in the Manual-Retrieve mode using the 'S6' command (see section *COMMAND*). In this mode, the PCOM-SDI transmits its response from the sensor to the host without attempting retrieval of the data with the D command. In Manual-Retrieve mode the host must issue both the 'aM!' command as well as the retrieve buffer command.

For example:

**Host command:** aM0!

**PCOM-SDI response to host:** a0051<CR><LF>

**Host command:** aD0! {host must issue the 'aD0!' command ttt= 5 seconds after the initial response}

**PCOM-SDI response to host:** a+<value><CR><LF>

### **3. SDI-12 PROTOCOL**

*NOTE: The PCOM-SDI handles the details of this protocol transparently to the user. Therefore, the following information is optional reading.*

In its standard configuration, the PCOM-SDI is a Master SDI-12 device. Alternatively, with some custom engineering, the PCOM-SDI can be configured to be a slave SDI-12 device (contact [sales@amassdata](mailto:sales@amassdata) for more information). In either case, a brief introduction to the SDI-12 protocol is presented here.

When the RS232 host sends a command to the AMASSER **PCOM-SDI** to initiate a measurement, the module becomes a Master SDI-12 controller until data is retrieved from the sensor. The SDI-12 slaves, that is the sensors, are then accessed as prescribed by the SDI-12 protocol.

In order to communicate with a SDI-12 sensor, the controller (PCOM module) sends a "break" signal, which consists of sending a spacing signal (5 V) for more than 12 millisecc. This will wake all sensors connected to the line. The AMASSER PCOM-SDI then sends the command that was submitted by the host onto the SDI-12 bus. The format of each byte of data is 1 start bit, 7 data bits with the least significant bit first, 1 parity bit with even parity, and 1 stop bit. The first significant byte of any message is the address of the sensor; all sensors with different addresses return to the "sleep" state and ignore the rest of the command. The last character of a command is always "!", and the controller turns off its transmitter within 7.5 millisecc after sending the "!". The sensor responds by setting the data line to marking (0 V) for 8.33 millisecc, and then begins its response. The first bit of the response must be sent within 15 millisecc of receiving the last byte of the command as prescribed in the SDI-12 protocol.

The response from the sensor contains information about a) the time that must elapse before the reading will be complete and ready for retrieval and b) the number of values returned by the sensor as a result of the command. The AMASSER PCOM-SDI then sends the "Send Data" (aD!) command to retrieve the data which it then returns to the host on the RS232 line (assuming Automatic-Retrieve mode).

**For detailed information on SDI-12 protocol visit the SDI-12 Support Group's web-site via our home page at <http://www.amassdata.com>.**

## 4. COMMANDS

### 4.1. Standard Set

➤ Identification command AI!

Command: 'AI!'

Response: 'A AMASS Data PCOM-SDI/157'

Provides the identification string of the PCOM-SDI. Includes the firmware version number (here '157').

➤ Configure for SDI-12 Auto-Retrieval mode (see section 2 HOST PROTOCOL)

Command: 'AS61!' (on, default) or 'AS60!' (off, Manual-retrieval mode)

Response: 'A'

➤ Read Current Mode

Command: 'AS6?!'

Response: 'A-on' or 'A-off'

Advises whether the "auto-retrieve mode" is enabled or disabled.

➤ Acknowledgment command A!

Command: 'A!'

Response: 'A'

Provides confirmation that communication between the RS232 device and the PCOM-SDI is established.

## 4.2. For SDI-12 Sensors

### ➤ Any Valid SDI-12 Command

Refer to section 2. HOST PROTOCOL. Ex. '0M0!', '0M2!' depending on the commands supported by the sensor and its address.

### 4.2.1. Error Messages

The PCOM-SDI provides error messages with respect to the SDI-12 communications between it and the SDI-12 device as follows:

<b>Error Message</b>	<b>Description</b>
Er0 - Adr/Cmd	An invalid command. For instance, an SDI-12 command which is not preceded with an address.
Er1 – NoCmdRsp	No response from sensor. This may be due to improper addressing, no power to the sensor, improper connections, etc...
Er2 – NoDORsp	The PCOM-SDI timed-out while waiting for a response to the 'D0' command, that is, the "retrieve data buffer" command.
Er3 - CmdRspCharTmout	The time-out timer expired due to a response to the 'M' command (or some form of SDI-12 measurement command) that was not conformant to the SDI-12 spec. The PCOM-SDI verifies total response time as well as byte-to-byte timing as per the SDI-12 specification. Non-conformant sensors are detected.
Er4 - DORspCharTmout	The time-out timer expired due to a response to the 'D0' command that was not conformant to the SDI-12 spec. The PCOM-SDI verifies total response time as well as byte-to-byte timing as per the SDI-12 specification. Non-conformant sensors are detected.
Er5 - TxCmdCharTmout	The time-out timer expired for the transmission of the measurement command.
Er6 - D0TxCharTmout	The time-out timer expired for the transmission of the 'D0' command.

## 5. “SPY” mode

The PCOM-SDI is equipped with a switch to enable “SPY” mode. This mode allows a user to monitor all SDI-12 communications on the bus by means of a computer or any other device with a RS232 serial port. In this configuration all of the SDI-12 messages between the SDI-12 logger and sensor(s) will be relayed to the RS232 device (typically a computer). Using a terminal emulator such as Hyperterminal, all of these messages will appear on the screen. Refer to the instructions below:

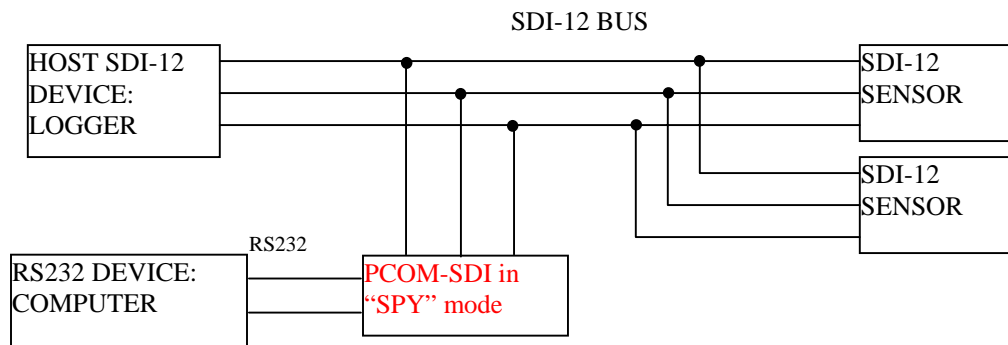

Figure 1. PCOM-SDI in "SPY" configuration.



Figure 2. Switch for "SPY" mode (shown in “normal” position).

### ENABLING “SPY” MODE

- Connect the PCOM-SDI as per Figure 2. Connect the SDI-12 bus, Ground and +12VDC:
  - WHITE :SDI-12
  - BLACK: Ground
  - RED: +12VDC
- Connect the PCOM-SDI RS232 connector (DB9S) to your computer serial port.
- Launch your communications application or terminal emulator (eg. Hyperterminal, ...). Set the communications to 9600 baud, 8 data bits, no parity, 1 stop bit.
- Ensure that the toggle switch is in “Normal” mode (see Figure 2)
- Confirm communications with the following command:
  - Command: AI!
  - Response: 13PCOM-SDI 157

- Set the PCOM-SDI to “SPY” mode with the following command:
  - Command: ASS!
  - Response: none issued
- Set the toggle switch to “SPY” mode.
- Now change the settings of your RS232 serial port to the following in order to monitor the SDI-12 bus:
  - 1200 baud
  - 7 data bits
  - even parity
  - 1 stop bit

Your terminal will now display activity on the SDI-12 bus. Return to “Normal” mode by setting the switch to “normal” mode and by cycling the power to the PCOM-SDI (i.e. performing a reset).

**NOTE:** The PCOM-SDI defaults to “normal” mode upon power-up. Therefore, the switch of the PCOM-SDI must be set to “normal” upon power-up (9600baud, 8 data bits, 1 stop bit, no parity).

## 6. INSTALLATION

### 6.1. Electrical

The PCOM-SDI power source must deliver between +8VDC and +30VDC.

Proper connection sequence is as follows:

- Connect the SDI-12 cable of the PCOM-SDI to the SDI-12 sensor(s): SDI-12 (white or green wire), Ground (Black) and +12VDC (Red).
- With the PCOM-SDI powered up you may then connect the DB9 connector to the RS232 serial port.

ALWAYS ENSURE THAT THE PCOM-SDI IS POWERED-UP BEFORE CONNECTING THE CABLE TO THE RS232 HOST. If this is not respected your serial communications device may “lock-up” and may need to be rebooted.

### 6.2. Connectors

- DB9S for connection to your serial port (RS232 communications )
- Tinned ends for SDI-12, +12VDC and Ground as follows:

<b>Color</b>	<b>Signal</b>
Red	+12VDC
White	SDI-12 data
Black	Ground

## 7. SPECIFICATIONS

Processor : Atmel 89S8252 @ 3.6864 MHz.  
Word Size : 8 bit data - 8 bit instruction  
Memory : 89S8252, 256 bytes RAM  
EEPROM 2 kbytes

### INPUT/OUTPUT of ALL PCOM MODULES

- ASCII strings via RS232 data line (standard configuration: RS232 master): 9600 baud, 8 data bits, 1 stop bit, no parity and no flow control  
Can also be configured for SDI-12 master
  - SDI-12 protocol (standard configuration):  
Master SDI-12 task engine, auto retries, auto data buffer retrieval & auto command time-outs.  
Can also be configured for RS232 slaves.
- Contact [sales@amassdata.com](mailto:sales@amassdata.com) for custom apps

### Connector

DB9S (RS232), tinned ends (Red:+12VDC,  
White:SDI-12 data, Black:Ground)

### Power Supply

Power supplied by a 8 to 30 VDC source.

### Power Consumption

10.5 mA without DB9 connected to host  
17.5mA with DB9 connected to host

### Environmental Characteristics

Operating : -40 to +55 C  
Storage : -60 to +100C  
Humidity : <= 100% non-condensing

### PHYSICAL CHARACTERISTICS

**PCOM-SDI:** Height - 25 mm. (1 in.)  
Width - 60 mm. (2.3 in.)  
Depth - 95 mm. (3.75 in.)

The above information is believed to be true at the time of printing. AMASS Data Technologies Inc. reserves the right to modify specifications without notice. All trademarks are owned by their respective companies.

AMASS Data Technologies Inc  
812 Proctor Ave., Box 707  
Ogdensburg, New York 13669  
USA  
Tel: 315-393-3793  
Fax: 315-393-9017  
E-mail: [sales@amassdata.com](mailto:sales@amassdata.com)

AMASS Data Technologies Inc.  
702 Route 105  
Chelsea QC J9B 1L2  
Canada  
Tel: 819-827-0077  
Fax: 819-827-4305  
E-mail: [sales@amassdata.com](mailto:sales@amassdata.com)